

# H3CR

## DIN Size W48 × H48mm

- Wide operating voltage range 100~240VAC or AC/DC 24~240V
- 8 field-selectable output modes for various applications
- 16 field-selectable time range, longest time 300 hours
- Short body design, about 68mm



### SPECIFICATIONS

MODEL	H3CR-A	H3CR-AS	H3CR-A-300	H3CR-A8	H3CR-A8E	H3CR-A8S
RATED VOLTAGE	100~240VAC			AC/DC 24~240V 50/60Hz		
FULL TIMING RANGE	SEC : 1.2/3/12/30 MIN : 1.2/3/12/30 HRS : 1.2/3/12/30 10H : 1.2/3/12/30					
INDICATOR OPERATING	Power-Green Output-Red					
OUTPUT METHOD	Time limit 2C 5A 250VAC Resistive Load	Time limit 1C (Transister)	Time limit 2C 5A 250VAC Resistive Load	Time limit 2C 5A 250VAC Resistive Load	Time limit 1C Instantaneous 1C 5A 250VAC Resistive Load	Time limit 1C (Transister)
OPERATING MODE	A : Signal ON delay B : Flicker OFF start B2: Flicker ON start C : Signal ON-OFF delay D : Signal OFF delay E : Signal ON interval		G : Signal ON-OFF delay J : One-shot output	A : Signal ON delay B2: Flicker ON start E : Signal ON interval J : One-shot output		
PIN TYPE	11 PIN			8 PIN		
L I F E	MECHANICAL	5 × 10 <sup>6</sup> times				
	ELECTRICAL	10 <sup>5</sup> times				
RESET TIME	0.1 sec max					
CONSUMED POWER	Max. 3VA					
AMBIENT TEMPERATURE	-10°C ~ + 55°C					
AMBIENT HUMIDITY	45 ~ 85%RH					
WEIGHT	Approx. 130g					

CONNECTION DIAGRAMS & TIMING CHARTS

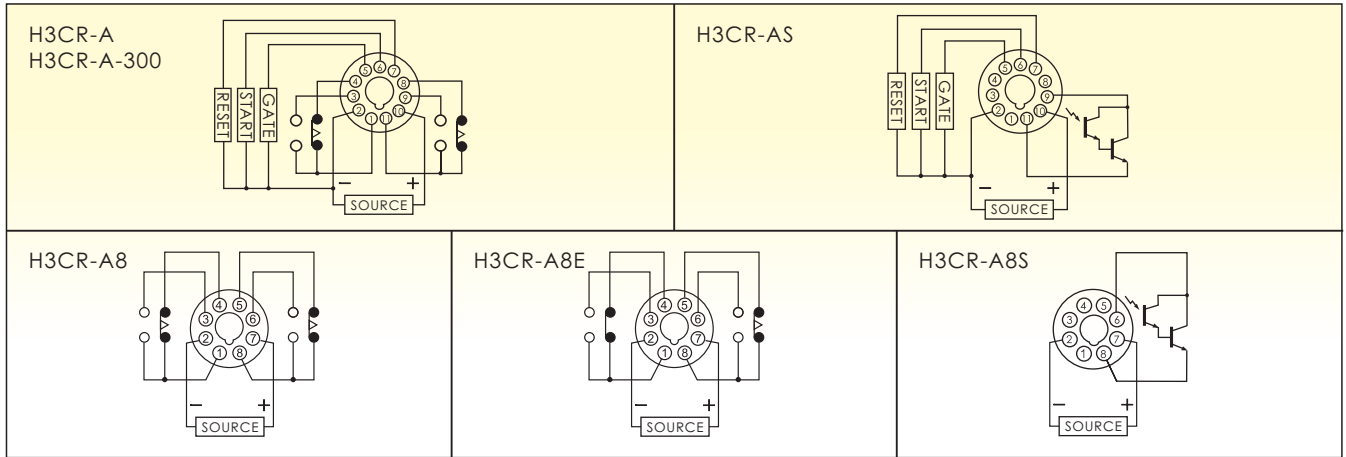

H3CR-A

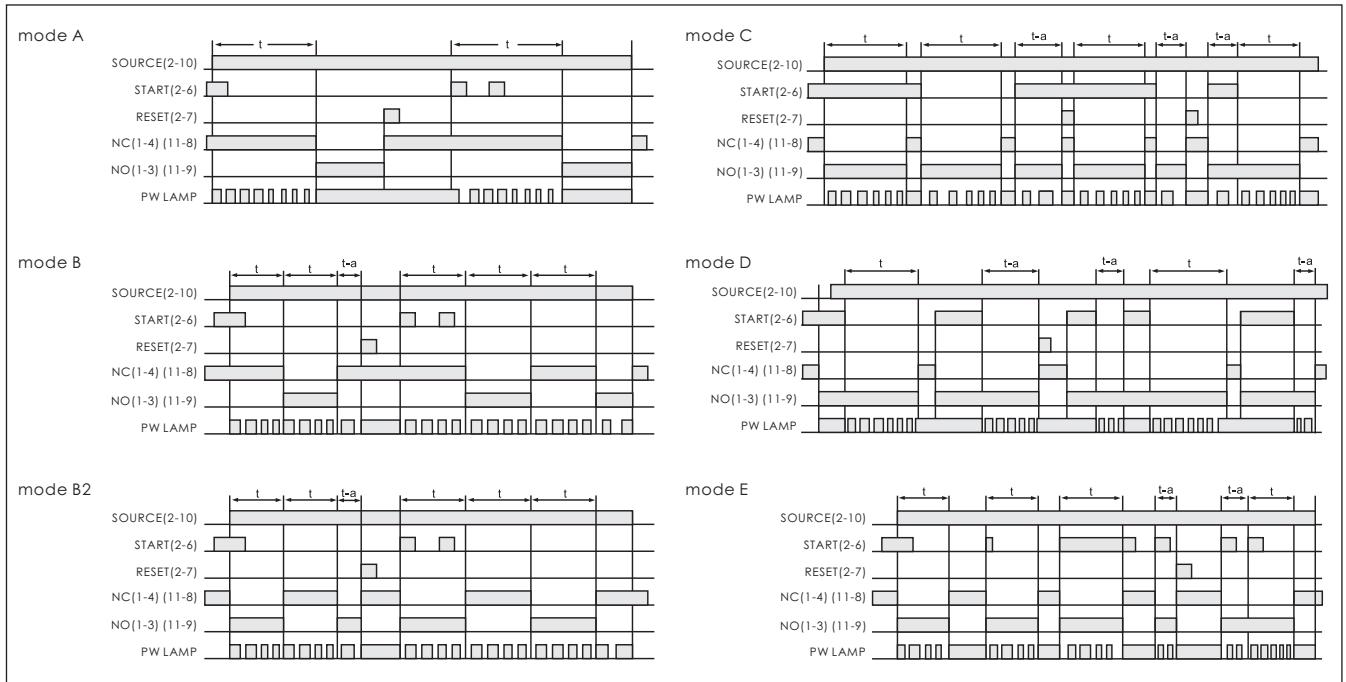

H3CR-A-300

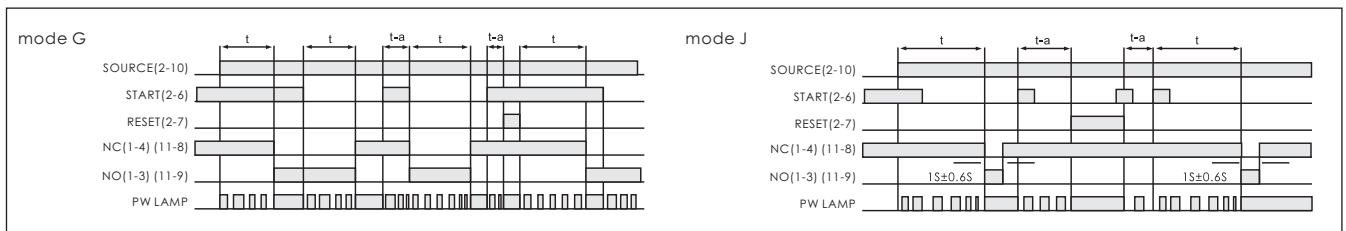

H3CR-A8

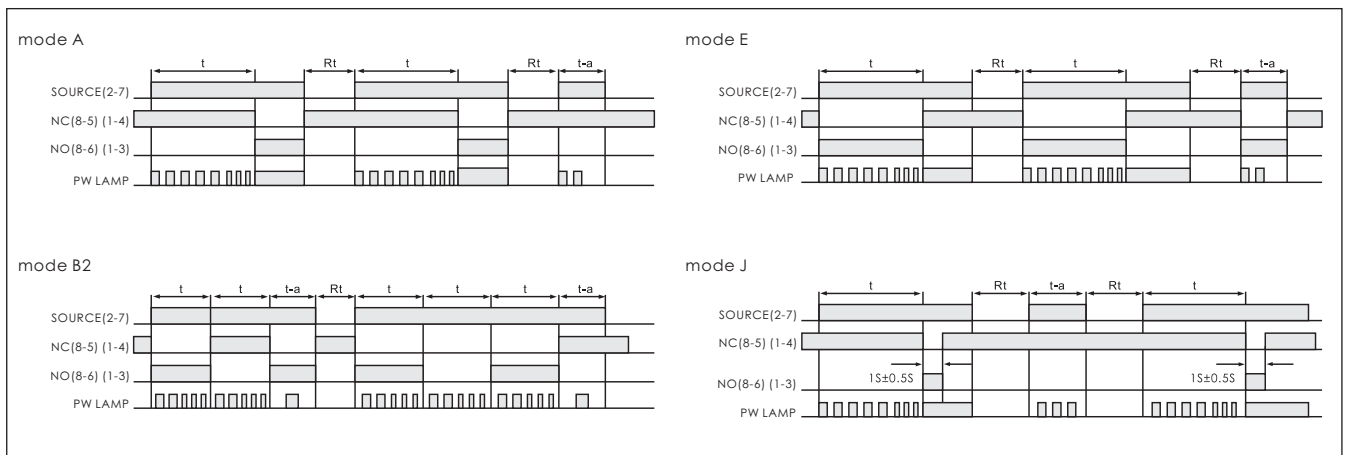

H3CR-A8E

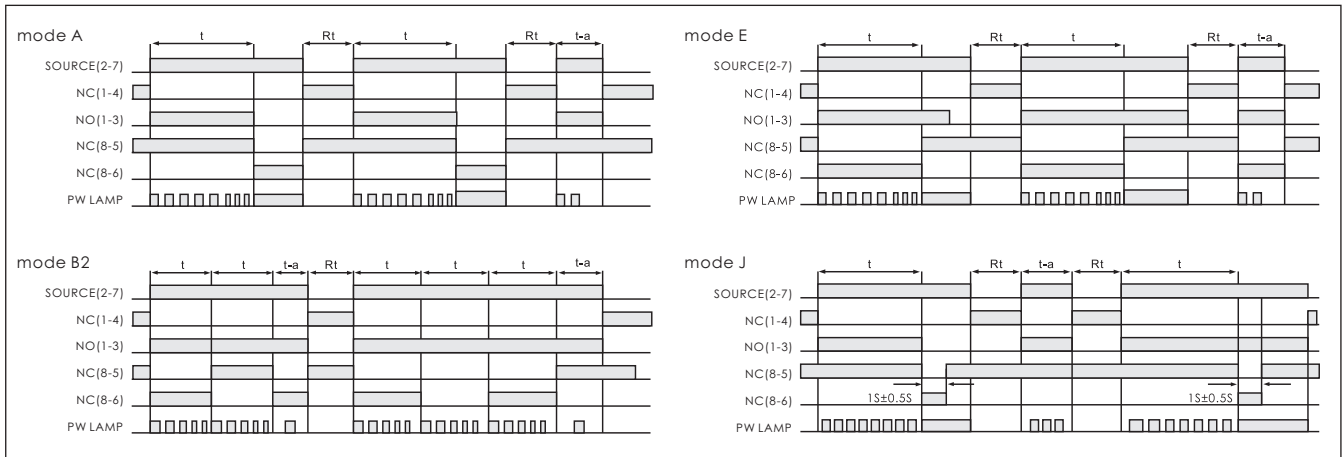

**GATE USE METHOD**

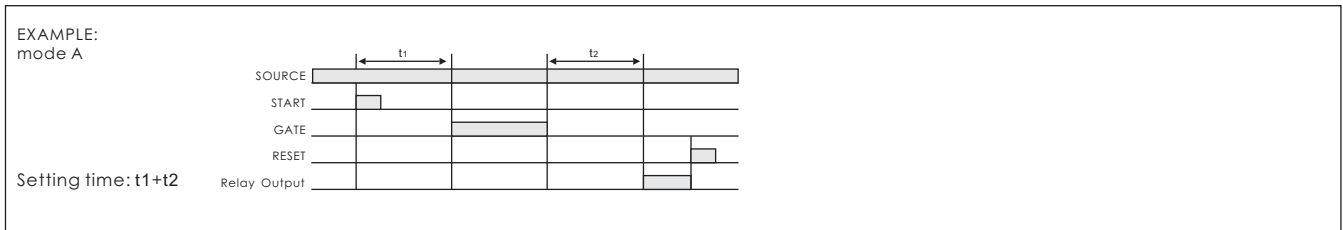

**DIMENSIONS**

Surface Mounting ( N Type ) : Using P2CF-08 or PF085A,PF085A-E or PF113A,PF113A-E Socket

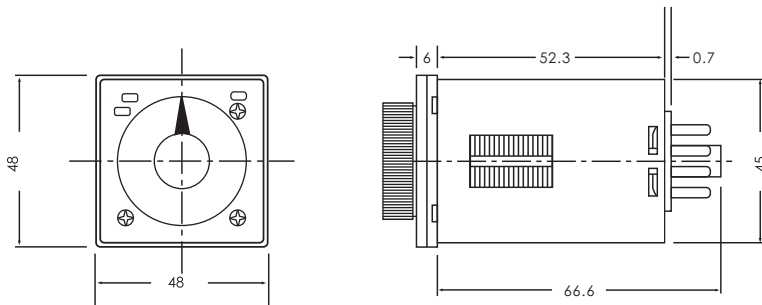

Flush Mounting ( Y Type ) : Using Y-50 Adapter+US-08 or P3G-08,P3G-08E,or P3G-11 Socket

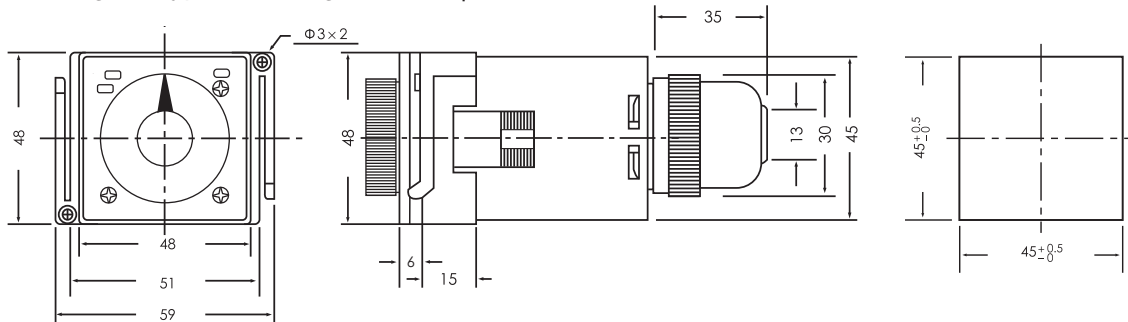

**ANV ELECTRIC CO., LTD.**

**Kaohsiung Headquarter**

No. 151, Jin Shan Road, Kaohsiung, Taiwan  
Tel :+886 7 359 5833 Fax :+886 7 359 5822  
E-Mail : anv@anv.com.tw

**Taipei Office**

No. 166, Fu Xing 3rd Street, Taishan Dist.,  
New Taipei City, Taiwan  
Tel :+886 2 2296 3133 Fax :+886 2 2296 3233  
E-Mail : taipei@anv.com.tw

**Tainan Office**

No. 60, Lin Sen Road Sec. 1, Tainan, Taiwan  
Tel:+886 6 216 0988 Fax:+886 6 216 0388  
E-Mail : tainan@anv.com.tw

**ANV ELECTRIC (HK) LTD**

Flat 4, 14/F., Block 4, Wai Wah Centre,  
Shatin, N.T., Hong Kong  
Tel :+852 2690 2588 Fax :+852 2690 2511  
E-Mail : anv@anv.com.hk

**Taichung Office**

No. 532, Wen Hsin Road Sec. 1, Taichung, Taiwan  
Tel :+886 4 2320 9930 Fax :+886 4 2320 9960  
E-Mail : taichung@anv.com.tw

**ANV ELECTRIC (M) SDN. BHD**

25-1, Jalan 1/116B, Kuchai Entrepreneur's Park,  
Off Jalan Kuchai Lama, 58200 Kuala Lumpur, Malaysia  
Tel :+60 3 7980 3328 Fax :+60 3 7980 3779  
E-Mail : anv@anv.com.my